

Архангельск (8182)63-90-72
Астана (7172)727-132
Астрахань (8512)99-46-04
Барнаул (3852)73-04-60
Белгород (4722)40-23-64
Брянск (4832)59-03-52
Владивосток (423)249-28-31
Волгоград (844)278-03-48
Вологда (8172)26-41-59
Воронеж (473)204-51-73
Екатеринбург (343)384-55-89
Иваново (4932)77-34-06

Ижевск (3412)26-03-58
Иркутск (395)279-98-46
Казань (843)206-01-48
Калининград (4012)72-03-81
Калуга (4842)92-23-67
Кемерово (3842)65-04-62
Киров (8332)68-02-04
Краснодар (861)203-40-90
Красноярск (391)204-63-61
Курск (4712)77-13-04
Липецк (4742)52-20-81
Киргизия (996)312-96-26-47

Магнитогорск (3519)55-03-13
Москва (495)268-04-70
Мурманск (8152)59-64-93
Набережные Челны (8552)20-53-41
Нижний Новгород (831)429-08-12
Новокузнецк (3843)20-46-81
Новосибирск (383)227-86-73
Омск (3812)21-46-40
Орел (4862)44-53-42
Оренбург (3532)37-68-04
Пенза (8412)22-31-16
Казахстан (772)734-952-31

Пермь (342)205-81-47
Ростов-на-Дону (863)308-18-15
Рязань (4912)46-61-64
Самара (846)206-03-16
Санкт-Петербург (812)309-46-40
Саратов (845)249-38-78
Севастополь (8692)22-31-93
Симферополь (3652)67-13-56
Смоленск (4812)29-41-54
Сочи (862)225-72-31
Ставрополь (8652)20-65-13
Таджикистан (992)427-82-92-69

Сургут (3462)77-98-35
Тверь (4822)63-31-35
Томск (3822)98-41-53
Тула (4872)74-02-29
Тюмень (3452)66-21-18
Ульяновск (8422)24-23-59
Уфа (347)229-48-12
Хабаровск (4212)92-98-04
Челябинск (351)202-03-61
Череповец (8202)49-02-64
Ярославль (4852)69-52-93

<https://alaval.nt-rt.ru> || avb@nt-rt.ru

Alfa Laval Astepo Combibox

Compact cartoning system for use in the food and beverage industries

Introduction

The Combibox unit is a compact three-in-one cartoning system that integrates the carton erector, the bag loading and the carton closer.

Application

The Combibox system is ideal for use with a wide range of pumpable products — both liquid and viscous, food and non-food.

Benefits

- Space-saving design with three machines in one single frame: the carton box former, carton box inserter/bag loader and the carton box closer.
- Integrated control system.
- Handles both French and American closures.
- Change-overs from one bag size to another in a few minutes.

Design

The Combibox system is designed and built in accordance with EC regulations for safety protection. The equipment is made of AISI 316 stainless steel and the design allows easy access to all parts for cleaning using overheated water.

The Combibox system is operated via a PLC system. The components and software for the “no bag/no box – no filling” protection and the alarms for missing box and bag are standard functions. Another important standard function is the auto-diagnosis on the digital command panel and the synchronization functions with the aseptic and non-aseptic filler system in use.

The food bag is inserted using a food-grade Intralox tape belt and a funnel. This funnel can be changed to match the required format, and is mounted on pneumatic cylinders that open the flaps slightly to ease the fall of the bag inside the cardboard box. The system can be equipped with a hot-melt gluing group or two 50 mm (2-inch) taping groups.

The Combibox system is suitable for paper/plastic handles as well as perforated carton boxes.

Operator intervention is only necessary in order to adjust the machine to take boxes of different sizes/heights. This is a very simple operation that does not require skilled labour, because all adjustments are carried out using cranks with numerical



indices. The Combibox system is fitted with safety doors protection.

Working principle

The carton box erector automatically opens the box, folds the lower flaps and seals them with adhesive tape or hot glue. A gear motor controls the two principal linear movements of the machine. One of these is for withdrawing and opening the carton box, while the other is for movement during the sealing stage. The carton box flaps are opened and sealed by electropneumatic movements.

The carton feeding unit is of the step-feed type. The bag cartoner runs on a food-grade tape belt, installed on pneumatic cylinders that move the flaps sideways to make sure the bags fall gently into the carton to avoid friction and twisting.

As an option, it is possible to insert a pneumatic fork suitable for closing cardboard boxes with hot melt or adhesive tape. By moving up and down, this pushes the bags' corners inside the box before the last station.

The machine receives the boxes filled with the product straight from the loading. The closing and the application of tape or hot melt are fully automatic operations.

Dimensional drawing

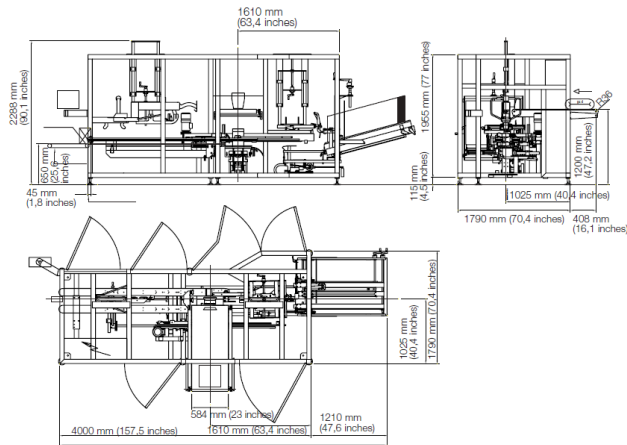

Technical data

Minimum box size	90 x 180 x 230 (h) mm 3.5 x 7.1 x 9.1 inches
Maximum box size	250 x 350 x 400 (h) 9.8 x 13.8 x 15.7 inches
Bag transport height from floor	1100 mm +/- 50 mm 43.3 inches ± 2 inches
Box transport height from floor	650 mm +/- 50 mm 25½ inches ± 2 inches
Production cycles per hour (base dimensions)	up to 700 depending on size
Format change time	~15 minutes
Electrical supply	3 x 400 V, 50 Hz, 5.5 kW with hot melt or 2 kW with tape
Air pressure in bar (PSI)	6 bar (87 PSI) 400 NL/min.
Dimensions (WxLxH)	1790 x 5210 x 1955 mm 70.4 x 205 x 77 inches
Weight	Max 1800 kg (3968 lb)
Capacity	3–20 litre (0.8–5.3 gallons) boxes

Архангельск (8182)63-90-72
Астана (7172)727-132
Астрахань (8512)99-46-04
Барнаул (3852)73-04-60
Белгород (4722)40-23-64
Брянск (4832)59-03-52
Владивосток (423)249-28-31
Волгоград (844)278-03-48
Вологда (8172)26-41-59
Воронеж (473)204-51-73
Екатеринбург (343)384-55-89
Иваново (4932)77-34-06

Ижевск (3412)26-03-58
Иркутск (395)279-98-46
Казань (843)206-01-48
Калининград (4012)72-03-81
Калуга (4842)92-23-67
Кемерово (3842)65-04-62
Киров (8332)68-02-04
Краснодар (861)203-40-90
Красноярск (391)204-63-61
Курск (4712)77-13-04
Липецк (4742)52-20-81
Киригизия (996)312-96-26-47

Магнитогорск (3519)55-03-13
Москва (495)268-04-70
Мурманск (8152)59-64-93
Набережные Челны (8552)20-53-41
Нижний Новгород (831)429-08-12
Новокузнецк (3843)20-46-81
Новосибирск (383)227-86-73
Омск (3812)21-46-40
Орел (4862)44-53-42
Оренбург (3532)37-68-04
Пенза (8412)22-31-16
Казахстан (772)734-952-31

Пермь (342)205-81-47
Ростов-на-Дону (863)308-18-15
Рязань (4912)46-61-64
Самара (846)206-03-16
Санкт-Петербург (812)309-46-40
Саратов (845)249-38-78
Севастополь (8692)22-31-93
Симферополь (3652)67-13-56
Смоленск (4812)29-41-54
Сочи (862)225-72-31
Ставрополь (8652)20-65-13
Таджикистан (992)427-82-92-69

Сургут (3462)77-98-35
Тверь (4822)63-31-35
Томск (3822)98-41-53
Тула (4872)74-02-29
Тюмень (3452)66-21-18
Ульяновск (8422)24-23-59
Уфа (347)229-48-12
Хабаровск (4212)92-98-04
Челябинск (351)202-03-61
Череповец (8202)49-02-64
Ярославль (4852)69-52-93

<https://alaval.nt-rt.ru> || avb@nt-rt.ru