

Архангельск (8182)63-90-72
Астана (7172)727-132
Астрахань (8512)99-46-04
Барнаул (3852)73-04-60
Белгород (4722)40-23-64
Брянск (4832)59-03-52
Владивосток (423)249-28-31
Волгоград (844)278-03-48
Вологда (8172)26-41-59
Воронеж (473)204-51-73
Екатеринбург (343)384-55-89
Иваново (4932)77-34-06

Ижевск (3412)26-03-58
Иркутск (395)279-98-46
Казань (843)206-01-48
Калининград (4012)72-03-81
Калуга (4842)92-23-67
Кемерово (3842)65-04-62
Киров (8332)68-02-04
Краснодар (861)203-40-90
Красноярск (391)204-63-61
Курск (4712)77-13-04
Липецк (4742)52-20-81
Киргизия (996)312-96-26-47

Магнитогорск (3519)55-03-13
Москва (495)268-04-70
Мурманск (8152)59-64-93
Набережные Челны (8552)20-53-41
Нижний Новгород (831)429-08-12
Новокузнецк (3843)20-46-81
Новосибирск (383)227-86-73
Омск (3812)21-46-40
Орел (4862)44-53-42
Оренбург (3532)37-68-04
Пенза (8412)22-31-16
Казахстан (772)734-952-31

Пермь (342)205-81-47
Ростов-на-Дону (863)308-18-15
Рязань (4912)46-61-64
Самара (846)206-03-16
Санкт-Петербург (812)309-46-40
Саратов (845)249-38-78
Севастополь (8692)22-31-93
Симферополь (3652)67-13-56
Смоленск (4812)29-41-54
Сочи (862)225-72-31
Ставрополь (8652)20-65-13
Таджикистан (992)427-82-92-69

Сургут (3462)77-98-35
Тверь (4822)63-31-35
Томск (3822)98-41-53
Тула (4872)74-02-29
Тюмень (3452)66-21-18
Ульяновск (8422)24-23-59
Уфа (347)229-48-12
Хабаровск (4212)92-98-04
Челябинск (351)202-03-61
Череповец (8202)49-02-64
Ярославль (4852)69-52-93

<https://alaval.nt-rt.ru> || avb@nt-rt.ru

Alfa Laval Vortex DRS

Advanced cyclonic Dust Recovery System

Introduction

Powdered materials are often pneumatically transported into and around industrial processing facilities in dry bulk form. While pneumatic transport is a great method for providing handling speed and safety benefits, it can result in a lot of wasted product. Some industrial waste studies have indicated that as much as 15% of bulk product that is handled pneumatically can be lost to the environment in the form of dust. Most of this dusting occurs from the vent lines of bulk storage silos or receiving vessels during the filling process as high velocity air escapes the tank vent carrying dust. This product waste costs thousands of dollars and presents potential HSE issues and non-compliance with government environmental regulations. The Alfa Laval Vortex DRS is a simple but effective dust recovery system that utilizes proprietary, compact cyclone technology to passively separate and collect product dust from vented air into a conical pressure vessel. The recovered material can then be transported back into bulk storage and use.

Applications

The Alfa Laval Vortex DRS provides a safe and adaptable method of drastically limiting the amount of dust that is emitted into the environment during pneumatic transport through passive product recovery. It can be utilized in any industrial application where pneumatic transport is employed to move bulk powder into a receiving vessel and it is desired to use the recovered bulk powder instead of losing it in disposable filter cartridges. It also can serve as a pre-filter for pre-filter for cartridge collectors, baghouses, electrostatic precipitators, and wet scrubbers that may be required for zero discharge. Industrial applications include recovery of drilling fluid additives in oil and gas drilling, chemical processing, mining, and many others.

Benefits

- Simple robust design, no moving parts
- Effectively captures dust without filters or motors
- Recovers product for transfer back to usable storage
- Low maintenance
- Highly customizable to fit specific site applications



Standard Design

The Alfa Laval Vortex DRS is offered in two standard models. Model DR3500 consists of one 20" Spintop Air Cyclone mounted on top of a 1 cubic meter (35 cubic ft) 80 PSI pressure rated collection vessel. The DR7500 has two 20" Spintop Air Cyclones mounted on top of a 2.1 cubic meter (75 cubic ft) 80 PSI pressure rated collection vessel. Both models feature pneumatically controlled 4" slide gate valves positioned between the bottom discharge of the air cyclones and the 4" ports on the top of the vessel. These slide gate valves are used to seal the collection vessel for pressurizing and transporting the collected product back to usable bulk storage. Vibrating rod level sensors with flashing signal lights are used to indicate when the collection tank is full. Fluidizers are mounted in the cone of the collection vessel, along with a proprietary V-Slide® flow promoter device, which helps prevent bridging and rat-holing of bulk material during unloading. A Vortex Bulk Booster is connected to the bottom of the system to facilitate return of the collected product back to storage.

Working Principle

Dusty air or gas enters the tangential inlet of the Spintop Air Cyclone. As the dusty air spirals around the cyclone's uniquely designed vortex finder, centrifugal and gravitational forces work on the dust particles, sending them outward and

down the walls of the cyclone. The air forms a reverse vortex at the bottom of the cyclone and travels back up the center of the vortex finder and through the clean air exhaust. The dust particles fall out of the bottom of the cyclone and are collected inside the pressure vessel. Once the collection vessel

becomes full of recovered product, it can be pressurized and the recovered bulk material can be pneumatically transferred back to usable storage.

Technical Data

Model	DR3500	DR7500
Total tank volume	1 m ³ (35 ft ³)	2.1 m ³ (75 ft ³)
Working tank volume	.80 m ³ (28 ft ³)	1.68 m ³ (60 ft ³)
Dry weight (aprox.)	839 kg (1850 lbs)	1719 kg (3790 lbs)
Design temperature	-10°C to 50°C (14°F to 122°F)	-10°C to 50°C (14°F to 122°F)
Design pressure	5.5 bar (80 PSI)	5.5 bar (80 PSI)
Max operating pressure	4.9 bar (72 PSI)	4.9 bar (72 PSI)
Air handling capacity	1698 Sm ³ /hr (1000 Sf ³ /min)	3396Sm ³ /hr (2000 Sf ³ /min)
Separation efficiency	90%+ @ 1698 Sm ³ /hr	90%+ @ 3396 Sm ³ /hr

Dimensional Drawings

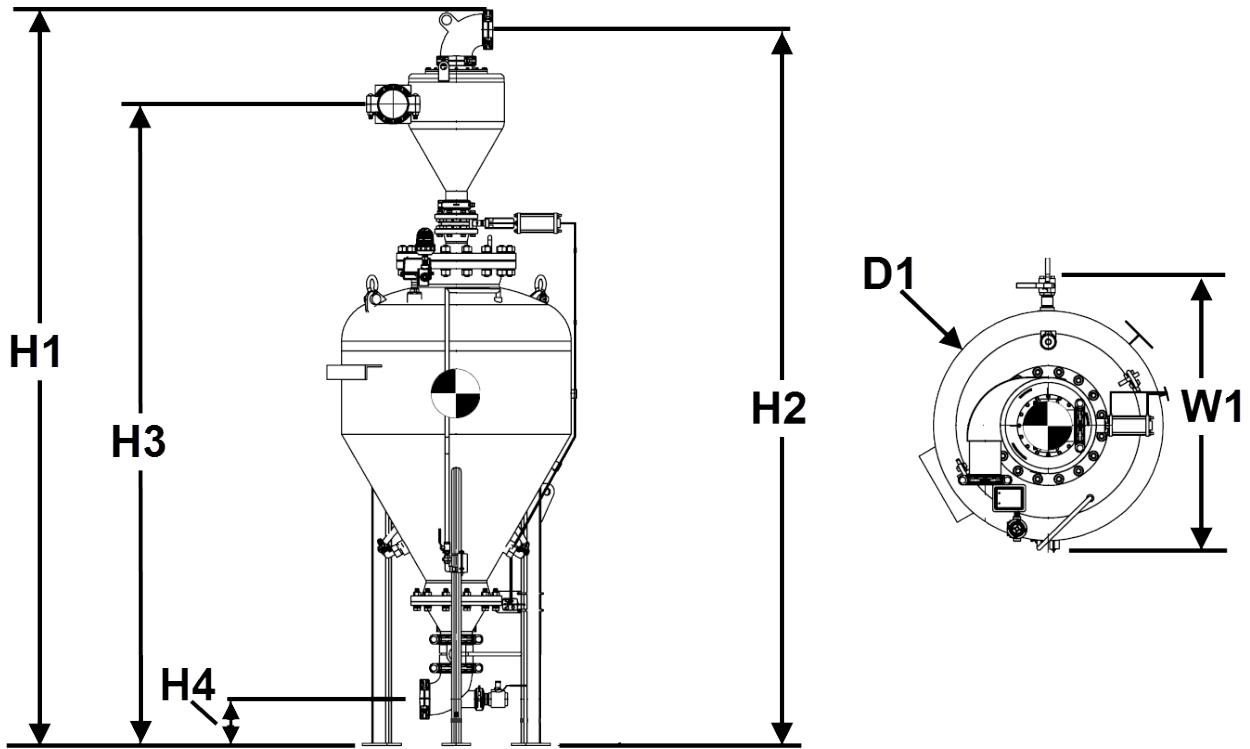

Model DR3500	
H1	3899 mm (153.5 in)
H2	3799 mm (149.5 in)
H3	3403 mm (134 in)
H4	246 mm (9.7 in)
D1	1219 mm (48 in)
W1	1461 mm (57.5 in)

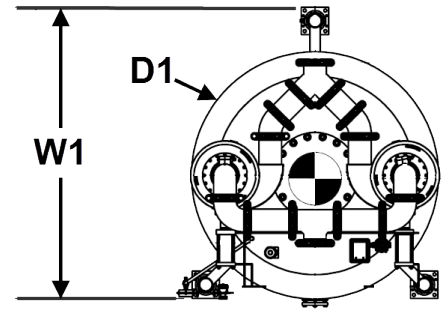
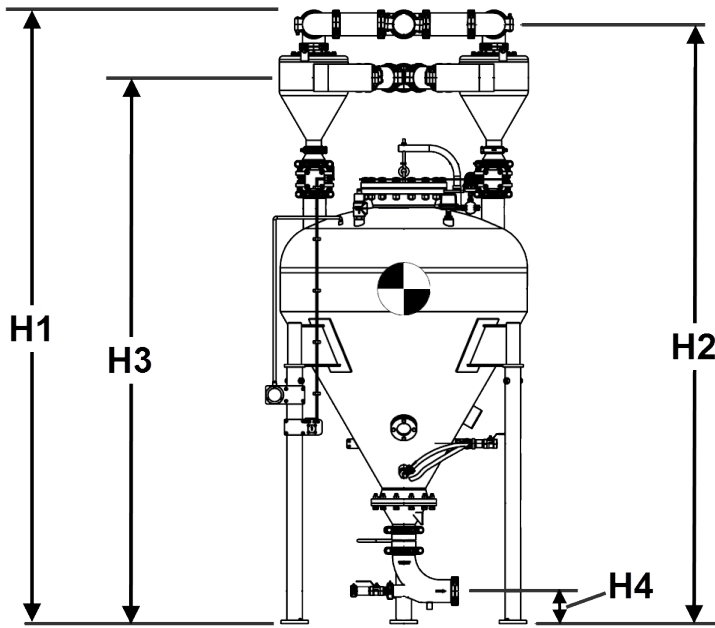

Model DR7500

H1	4563 mm (178.6 in)
H2	4428 mm (174.3 in)
H3	4037 mm (158.9 in)
H4	241 mm (9.5 in)
D1	1829 mm (72 in)
W1	2154 mm (84.8 in)

Архангельск (8182)63-90-72
 Астана (7172)727-132
 Астрахань (8512)99-46-04
 Барнаул (3852)73-04-60
 Белгород (4722)40-23-64
 Брянск (4832)59-03-52
 Владивосток (423)249-28-31
 Волгоград (844)278-03-48
 Вологда (8172)26-41-59
 Воронеж (473)204-51-73
 Екатеринбург (343)384-55-89
 Иваново (4932)77-34-06

Ижевск (3412)26-03-58
 Иркутск (395)279-98-46
 Казань (843)206-01-48
 Калининград (4012)72-03-81
 Калуга (4842)92-23-67
 Кемерово (3842)65-04-62
 Киров (8332)68-02-04
 Краснодар (861)203-40-90
 Красноярск (391)204-63-61
 Курск (4712)77-13-04
 Липецк (4742)52-20-81
 Киргизия (996)312-96-26-47

Магнитогорск (3519)55-03-13
 Москва (495)268-04-70
 Мурманск (8152)59-64-93
 Набережные Челны (8552)20-53-41
 Нижний Новгород (831)429-08-12
 Новокузнецк (3843)20-46-81
 Новосибирск (383)227-86-73
 Омск (3812)21-46-40
 Орел (4862)44-53-42
 Оренбург (3532)37-68-04
 Пенза (8412)22-31-16
 Казахстан (772)734-952-31

Пермь (342)205-81-47
 Ростов-на-Дону (863)308-18-15
 Рязань (4912)46-61-64
 Самара (846)206-03-16
 Санкт-Петербург (812)309-46-40
 Саратов (845)249-38-78
 Севастополь (8692)22-31-93
 Симферополь (3652)67-13-56
 Смоленск (4812)29-41-54
 Сочи (862)225-72-31
 Ставрополь (8652)20-65-13
 Таджикистан (992)427-82-92-69

Сургут (3462)77-98-35
 Тверь (4822)63-31-35
 Томск (3822)98-41-53
 Тула (4872)74-02-29
 Тюмень (3452)66-21-18
 Ульяновск (8422)24-23-59
 Уфа (347)229-48-12
 Хабаровск (4212)92-98-04
 Челябинск (351)202-03-61
 Череповец (8202)49-02-64
 Ярославль (4852)69-52-93

<https://alaval.nt-rt.ru> || avb@nt-rt.ru