

Архангельск (8182)63-90-72  
Астана (7172)727-132  
Астрахань (8512)99-46-04  
Барнаул (3852)73-04-60  
Белгород (4722)40-23-64  
Брянск (4832)59-03-52  
Владивосток (423)249-28-31  
Волгоград (844)278-03-48  
Вологда (8172)26-41-59  
Воронеж (473)204-51-73  
Екатеринбург (343)384-55-89  
Иваново (4932)77-34-06

Ижевск (3412)26-03-58  
Иркутск (395)279-98-46  
Казань (843)206-01-48  
Калининград (4012)72-03-81  
Калуга (4842)92-23-67  
Кемерово (3842)65-04-62  
Киров (8332)68-02-04  
Краснодар (861)203-40-90  
Красноярск (391)204-63-61  
Курск (4712)77-13-04  
Липецк (4742)52-20-81  
Киргизия (996)312-96-26-47

Магнитогорск (3519)55-03-13  
Москва (495)268-04-70  
Мурманск (8152)59-64-93  
Набережные Челны (8552)20-53-41  
Нижний Новгород (831)429-08-12  
Новокузнецк (3843)20-46-81  
Новосибирск (383)227-86-73  
Омск (3812)21-46-40  
Орел (4862)44-53-42  
Оренбург (3532)37-68-04  
Пенза (8412)22-31-16  
Казахстан (772)734-952-31

Пермь (342)205-81-77  
Ростов-на-Дону (863)308-18-15  
Рязань (4912)46-61-64  
Самара (846)206-03-16  
Санкт-Петербург (812)309-46-40  
Саратов (845)249-38-78  
Севастополь (8692)22-31-93  
Симферополь (3652)67-13-56  
Смоленск (4812)29-41-54  
Сочи (862)225-72-31  
Ставрополь (8652)20-65-13  
Таджикистан (992)427-82-92-69

Сургут (3462)77-98-35  
Тверь (4822)63-31-35  
Томск (3822)98-41-53  
Тула (4872)74-02-29  
Тюмень (3452)66-21-18  
Ульяновск (8422)24-23-59  
Уфа (347)229-48-12  
Хабаровск (4212)92-98-04  
Челябинск (351)202-03-61  
Череповец (8202)49-02-64  
Ярославль (4852)69-52-93

<https://alaval.nt-rt.ru> || [avb@nt-rt.ru](mailto:avb@nt-rt.ru)

# СГУСТИТЕЛИ, ФИЛЬТР-ПРЕССЫ И ФИЛЬТРЫ

## Alfa Laval AS-H Winklepress 97 belt filter press

### Sludge dewatering machine

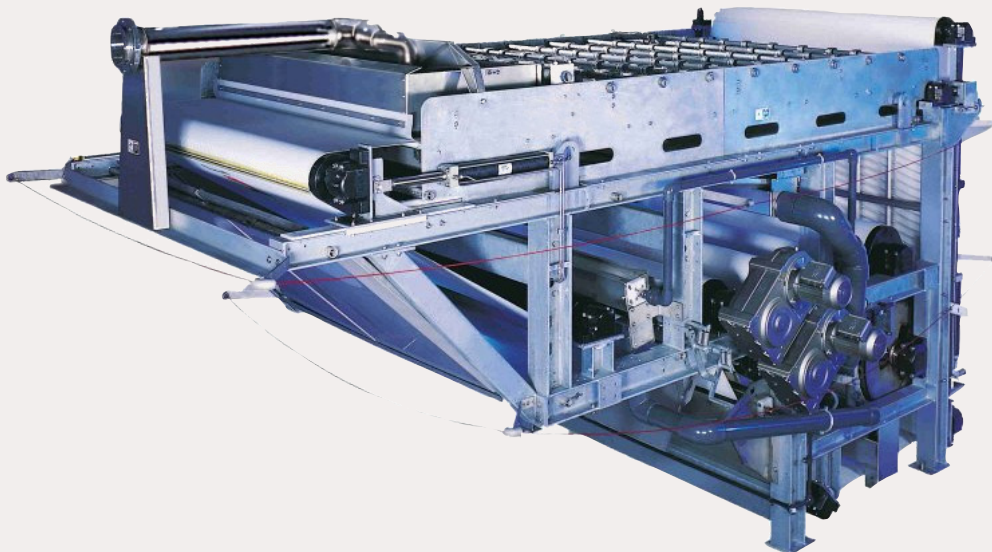

#### Application

The Alfa Laval AS-H Winklepress 97 is a high performance belt filter press used for dewatering in municipal and industrial wastewater applications. The unit uses specialized processing zones to achieve consistent cake dryness at high throughput volumes with low energy and polymer requirements.

#### Benefits

- Ideal for applications where high dry solids are required
- Low power requirement
- Low polymer cost
- Low maintenance requirements
- Long product life cycle
- Easy to upgrade in the field with additional pressure zone rollers
- Consistent cake dryness at high throughput

#### Configurations

- Available with high solids pressure zone to provide maximum cake dryness
- Extended gravity deck is available for dilute sludges

## Working principle – optimized zone approach

There are six key zones that allow the Winklepress 97 to optimize the dewatering process:

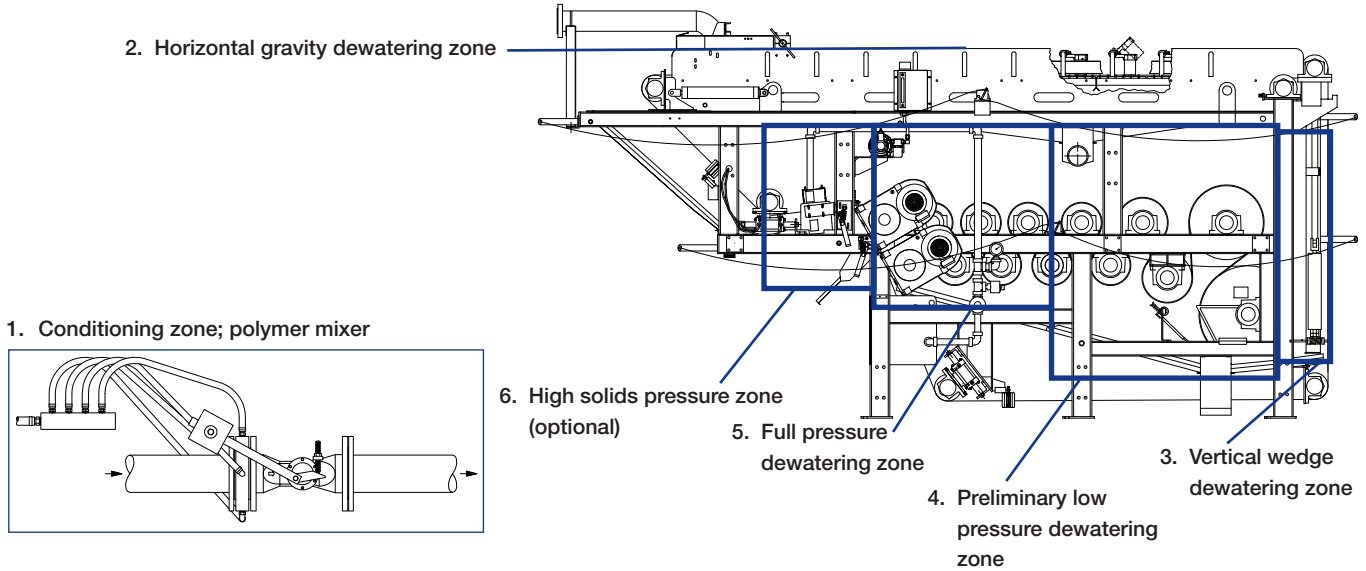

**1. Conditioning zone** – optimized dewatering begins with the proper conditioning of the slurry. Each unit is equipped with a proprietary variable orifice in-line polymer mixer that combines polymer and slurry instantly to facilitate rapid flocculation. This design allows the unit to use the lowest dosage of polymer while achieving the highest cake solids.

**2. Horizontal gravity dewatering zone** – multiple rows of chicanes and the belt support grid system quickly removes excess liquids. The chicanes continuously turn the sludge over, freeing up entrapped liquid, and creating an open area to allow the entrapped water to exit to the dewatering belt. The grid system supports the belt, while creating a wiping action on the bottom of the belt to enhance drainage rates. Extended gravity zones are available for more dilute slurries.

**3. Vertical wedge dewatering zone** – allowing for dewatering through both belts as they converge, the system is spring loaded and fully adjustable, even while the machine is in operation.

**4. Preliminary low pressure dewatering zone** – occurring at the dandy roller (a specially designed perforated roller with internal scoops that aids with filtrate removal), a gradual buildup of pressure on the sludge begins, preparing the process for the full pressure zone.

**5. Full pressure dewatering zone** – pressure levels gradually increase as the sludge moves between the two belts. By progressively reducing the roller diameters, the shear effect and pressure is accelerated. As the amount of pressure applied to the sludge between the dewatering belts increases, the shear action acts to break the cake structure and expose fresh areas to surface pressure. The end product is a uniformly dry sheet of cake that discharges from the machine.

**6. High solids pressure zone (optional)** – designed to provide maximum cake dryness, this section increases the time under pressure and adds shear to deliver approximately a 10-20% dryer cake.

## Performance features

- The Alfa Laval AS-H Winklepress 97 is fitted with lifetime rated bearings. Each bearing is protected from contaminants with a triple labyrinth seal and specially designed shaft mounted splash guards. Lubrication is only required every six months of operation time.
- Featuring a fully live belt alignment and tensioning system, the unit incorporates a pressure compensated variable flow pump. This advanced system only requires a 3.8 liter (1 gallon) fluid reservoir. The entire system comes mounted to the machine pre-piped and pre-wired – eliminating civil work and the need to run any additional lines.
- The sludge/polymer mixer valve used instantly combines the polymer and slurry. This non-clog, static mixer is known for its mixing precision and adjustable throat, which allow direct control of mixing energy. The design optimizes polymer effectiveness and minimizes polymer consumption.
- The Alfa Laval AS-H Winklepress 97 design and drain pan configurations simplify cleanup procedures and increase access to key areas. Clean operation is enhanced by the patented scraper blade design that places even edge loading across the blade with springs and operator levers on both ends of the blade. Also, the cake side of the belt never runs against the roller face, minimizing material transfers.

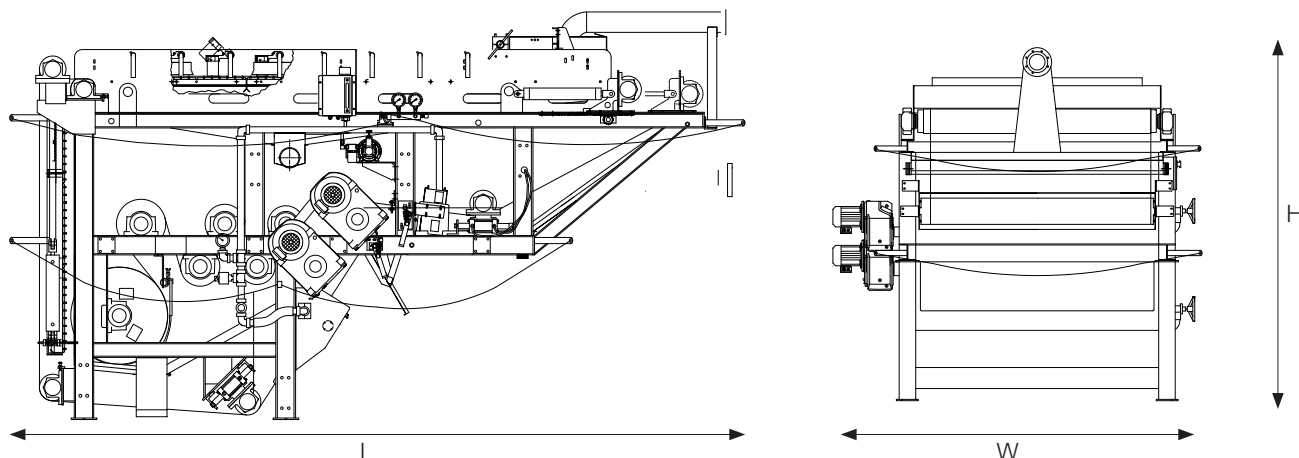

### Dimensions - standard model

Model	Length		Width		Height	
	mm	inches	mm	inches	mm	inches
2.0 STD	6,045	238	3,581	141	2,750	138

### Dimensions - with optional high solids pressure zone

Model	Length		Width		Height	
	mm	inches	mm	inches	mm	inches
2.0 HS	6,680	263	3,581	141	2,750	138

Архангельск (8182)63-90-72  
 Астана (7172)727-132  
 Астрахань (8512)99-46-04  
 Барнаул (3852)73-04-60  
 Белгород (4722)40-23-64  
 Брянск (4832)59-03-52  
 Владивосток (423)249-28-31  
 Волгоград (844)278-03-48  
 Вологда (8172)26-41-59  
 Воронеж (473)204-51-73  
 Екатеринбург (343)384-55-89  
 Иваново (4932)77-34-06

Ижевск (3412)26-03-58  
 Иркутск (395)279-98-46  
 Казань (843)206-01-48  
 Калининград (4012)72-03-81  
 Калуга (4842)92-23-67  
 Кемерово (3842)65-04-62  
 Киров (8332)68-02-04  
 Краснодар (861)203-40-90  
 Красноярск (391)204-63-61  
 Курск (4712)77-13-04  
 Липецк (4742)52-20-81  
 Киргизия (996)312-96-26-47

Магнитогорск (3519)55-03-13  
 Москва (495)268-04-70  
 Мурманск (8152)59-64-93  
 Набережные Челны (8552)20-53-41  
 Нижний Новгород (831)429-08-12  
 Новокузнецк (3843)20-46-81  
 Новосибирск (383)227-86-73  
 Омск (3812)21-46-40  
 Орел (4862)44-53-42  
 Оренбург (3532)37-68-04  
 Пенза (8412)22-31-16  
 Казахстан (772)734-952-31

Пермь (342)205-81-47  
 Ростов-на-Дону (863)308-18-15  
 Рязань (4912)46-61-64  
 Самара (846)206-03-16  
 Санкт-Петербург (812)309-46-40  
 Саратов (845)249-38-78  
 Севастополь (8692)22-31-93  
 Симферополь (3652)67-13-56  
 Смоленск (4812)29-41-54  
 Сочи (862)225-72-31  
 Ставрополь (8652)20-65-13  
 Таджикистан (992)427-82-92-69

Сургут (3462)77-98-35  
 Тверь (4822)63-31-35  
 Томск (3822)98-41-53  
 Тула (4872)74-02-29  
 Тюмень (3452)66-21-18  
 Ульяновск (8422)24-23-59  
 Уфа (347)229-48-12  
 Хабаровск (4212)92-98-04  
 Челябинск (351)202-03-61  
 Череповец (8202)49-02-64  
 Ярославль (4852)69-52-93